

**SENJU SPRINKLER CO.,LTD.**

**Flush Pendent Sprinkler**  
**Standard Response, Standard Coverage.**  
**Model ZN-UF, K=5.6 (SIN / SS2531)**

**General Description**

The Model ZN-UF Flush Pendent Sprinklers are automatic sprinklers of the compressed fusible solder type. They are decorative, low profile, flush mount sprinklers. The Frame and Cover of the sprinkler hide the Deflector and Gasket assemblies. (Reference Figure 1)

The Model ZN-UF is designed for use in Commercial occupancies. When aesthetics is the major consideration, the Model ZN-UF should be your first choice.

They are to be used in wet pipe sprinkler systems per NFPA 13.

The Model ZN-UF has a 5.6 (80.0) K-factor.

The Flush design of the Model ZN-UF features a separable escutcheon providing 3/8 inch (9.5 mm) vertical adjustment.

This adjustment reduces the accuracy to which the fixed pipe drops to the sprinklers must be cut to help assure a perfect fit installation.

The Model ZN-UF has been designed with heat sensitivity (Standard Response) and water distribution characteristics proven to help in the control of fires to improve the chance for occupants to escape or be evacuated. However, fire sprinkler systems are not a substitute for intelligent fire safety awareness or fire safety construction required by building codes.

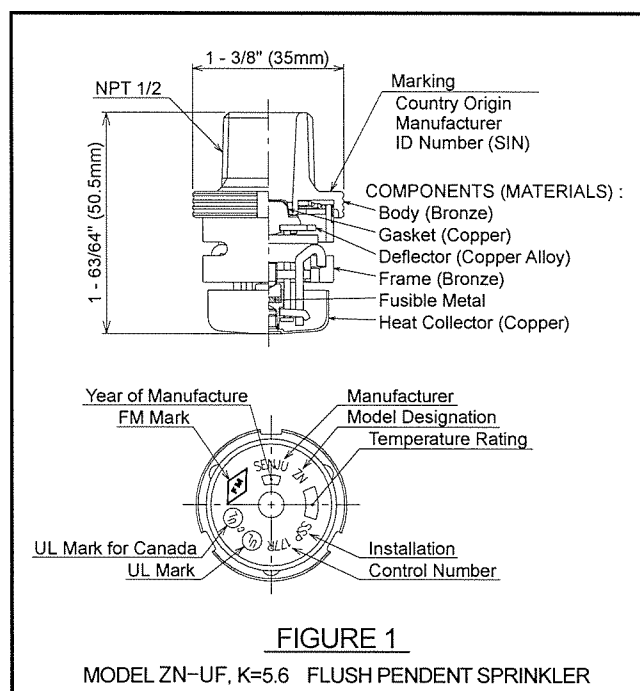
**WARNINGS**

*The Model ZN-UF Commercial Flush Pendent Sprinklers described herein must be installed and maintained in compliance with this document, as well as with the applicable standards of the National Fire Protection Association, in addition to the standards of any other authorities having jurisdiction. Failure to do so may impair the integrity of these devices.*

*Because of the above cited stipulations and the varied nature of architecture, there will be some compartment designs which cannot be fully sprinklered in accordance with the recommendations of NFPA 13.*

*In the event of this condition, consult the authorities having jurisdiction for guidance and approval.*

*It is the responsibility of the installing contractor to provide a copy of this document to the owner or his representative, and in turn, it is the obligation of the owner to provide a copy of this document to a succeeding owner.*

*The owner is responsible for maintaining their fire protection system and devices in proper operating condition. The installing contractor or sprinkler manufacturer should be contacted relative to any questions.*

**Technical Data****Approvals:**

FM Approved.  
 UL and ULC Listed. NYC MEA136-04-E.

**Sprinkler Identification Number:**

SIN SS2531

**Maximum Working Pressure:**

175 psi (12.1 bar)

**Discharge Coefficient:**

K = 5.6 GPM / psi<sup>1/2</sup> (80.0 LPM / bar<sup>1/2</sup>)

**Temperature Rating:**

162 °F / 72 °C  
 205 °F / 96 °C  
 282 °F / 139 °C ( 282°F : UL / ULC Listed only )

**Vertical Adjustment:**

3/8 inch (9.5 mm)

**Finishes:**

Sprinkler and Escutcheon:  
 White Painted, Black Painted, Chrome Plated.

**Physical Characteristics:**

Dezincification resistant bronze body and copper gasketed orifice seal (Metal Sealing) design.

## Operation

The Sprinkler assembly contains a small fusible solder element. When exposed to sufficient heat from a fire, the solder melts and enables the internal components of the sprinkler to fall away. At this point the sprinkler activates with the deflector dropping into its operated position (Reference Figure 2), permitting water to flow.

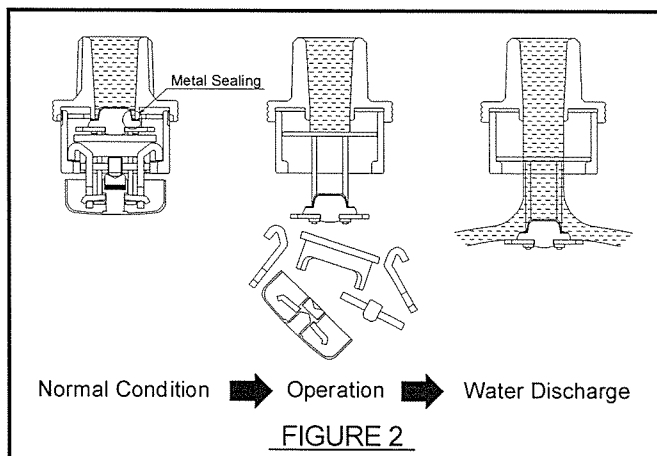

## Design Criteria

The Model ZN-UF Flush Pendent Sprinklers must only be installed and utilized in accordance with the following described criteria, which are provided by the manufacturer.

## NOTES

*Fire Sprinkler Systems should only be designed and installed by those component and completely familiar with automatic sprinkler system design, installation procedures, and techniques.*

*The Model ZN-UF Flush Pendent Sprinklers are intended for fire protection systems designed in accordance with the standard installation rules recognized by the applicable Listing or Approval agency (e.g., UL Listing is based on NFPA 13 requirements).*

*Several criteria may apply to the installation and usage of each sprinkler. Consequently, it is recommended that the sprinkler system designer review and develop a working understanding of the complete list of criteria prior to initiating the design of the sprinkler system.*

*Questions concerning sprinkler installation and usage criteria, which are not coverage by the following instructions, should be submitted to Contact Company. Include sketches and technical details as appropriate.*

*In some instances, the requirements of this document may concern specifications which are more stringent and which take precedence over those specified in NFPA 13 or by the authority having jurisdiction.*

*The spray from the sprinkler is distributed radially outward and downward from the sprinkler deflector. Consequently, the sprinklers must be located such that there will not be any blind spaces shielded from spray by partitions, room dividers, overhangs or other parts of the dwelling structure.*

*The number of sprinklers within each compartment (as defined by NFPA 13,) must be kept as few as possible. Do NOT use more sprinklers than necessary to cover a particular space.*

*Use only the escutcheon provided with the Model ZN-UF. The sprinkler must be secured in position by firmly fastening the sprinkler system piping to the structure. If the sprinkler is not properly secured in position, reaction forces resulting from sprinkler operation could alter its orientation and its water distribution pattern.*

*The sprinkler escutcheon cannot be used to hold the sprinkler in position.*

*The Model ZN-UF must only be utilized in wet pipe sprinkler systems.*

## Obstruction to Water Distribution

Locations of sprinklers are to be in accordance with the obstruction rules of NFPA 13.

## Precautionary Warnings for Corrosive Environments

Model ZN-UF should not be installed where they may be subjected to a corrosive environment including the following:

### 1) Chlorine ion and Chloride environment.

Stress corrosion cracking may be caused by exposure to environments with Chlorine ion and Chloride. Exposure to this environment may result in sprinklers operating under non-fire conditions or not operating when exposed to an actual fire.

### 2) Sprinkler system piping with Copper.

Sprinkler systems should be constructed in compliance with the applicable standards and the requirements for the copper piping when copper piping is used in the sprinkler system. (Reference standards NFPA 13, ASTM B813, ASTM B828, and CDA (Copper Development Association) – Solder Joint)

All residual flux must be removed from the interior and exterior of copper piping by thoroughly flushing before installation of the Sprinkler Heads. Otherwise, residues of flux may cause corrosion and leakage in the sprinkler system.

## Operational Sensitivity Criteria

For proper operational sensitivity, the model ZN-UF must be installed beneath a solid ceiling having a smooth or textured surface.

## Heat Source Criteria

Refer to NFPA 13 for the requirements relating to preventing the possible release of a Model ZN-UF heat responsive element, due to exposure to heat sources other than an actual fire.

## Installation

The Model ZN-UF must be installed in accordance with the following instructions:

## NOTES

*Do not use sprinklers which have been subjected to potential mechanical damage. Do not use sprinklers which show deformation or cracking in either the sprinkler or protection cap.*

*The Protective Cap must remain on the sprinkler during installation and until the ceiling installation is completed. The Protective Cap must be removed to place the sprinkler in service.*

*A leak tight 1/2-inch NPT sprinkler joint should be obtained with a torque of 7 to 14 ft.lbs. (9.5 to 19.0 Nm). A maximum of 21 ft.lbs. (28.5 Nm) of torque is to be used to install sprinklers. Higher levels of torque may distort the sprinkler inlet with consequent leakage or impairment of the sprinkler.*

*Do not attempt to compensate for insufficient adjustment in an Escutcheon Plate by under- or over-tightening the sprinkler. Readjust the position of the sprinkler fitting to suit.*

**Installing procedure**

**Step 1.**

The sprinkler must be installed only in the pendent position and with the Sprinkler waterway centerline perpendicular to the mounting surface.

**Step 2.**

Install the sprinkler fitting so that the distance from the face of the fitting to the mounting surface will be nominally 1- 5/32 inch as shown in Figure 3.

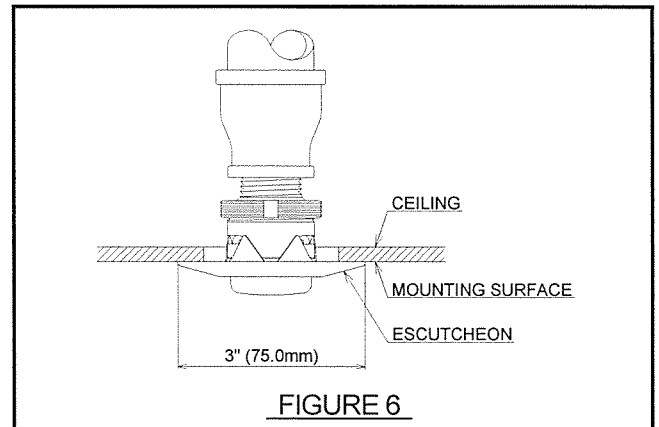
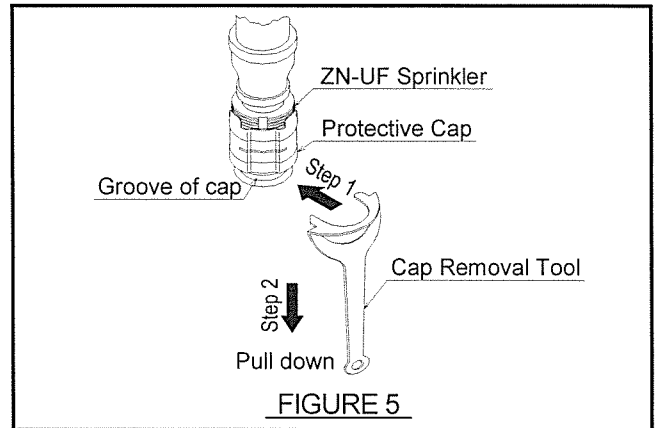
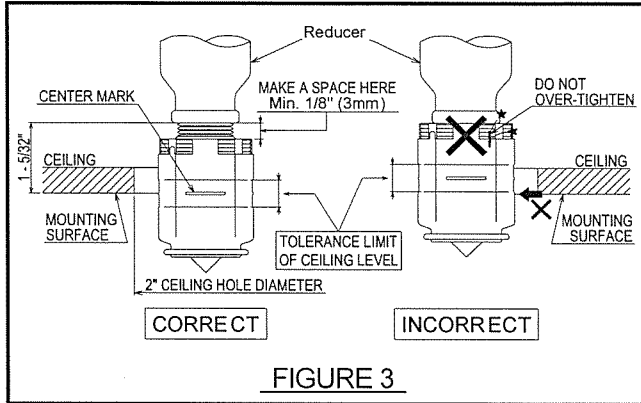

**Step 3.**

With pipe thread sealant applied to the pipe threads, hand tighten the Sprinkler into the sprinkler fitting.

**Step 4.**

Wrench tighten the Sprinkler using only the Sprinkler Socket or Wrench & Socket Combination (Ref. Figure 4). The wrench recess of the Socket is to be applied to the sprinkler wrenching area (Ref. Figure 4).

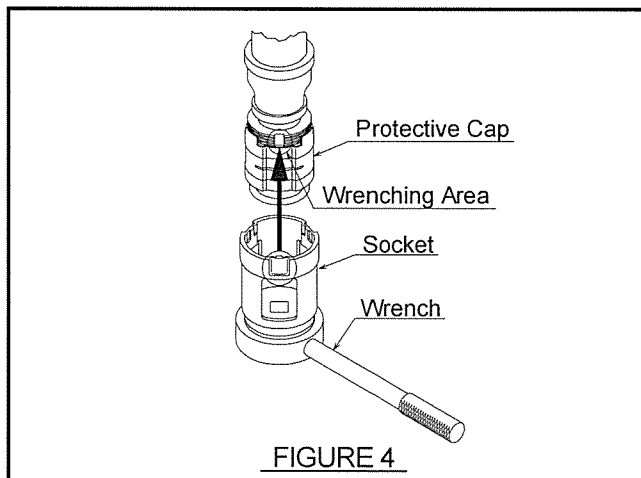

Do not continue to push on the Escutcheon such that it lifts a ceiling panel out of its normal position. If the Escutcheon cannot be engaged with the Sprinkler, or the Escutcheon cannot be engaged sufficiently to contact the ceiling, relocate the sprinkler fitting as necessary.

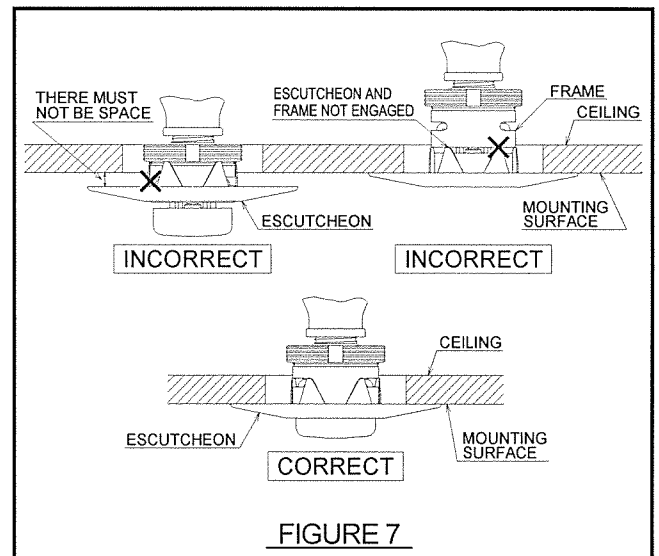

**Step 5.**

Use the "tolerance limit of ceiling level" indicator on the Protective Cap to check for proper installation height (Ref. Figure 3). Relocate the sprinkler fitting as necessary. If desired the Protective Cap may also be used to locate the center of the clearance hole by gently pushing the ceiling material against the center point of the Cap.

**Step 6.**

After the ceiling has been completed with the 2-inch (50mm) diameter clearance hole, use the Protective Cap Removal Tool (Ref. Figure 5) to remove the Protective Cap and then push on the Escutcheon until its flange just comes in contact with the ceiling (Ref. Figure 6 & Figure 7).

## Care and Maintenance

The Model ZN-UF must be maintained and serviced in accordance with the following instructions:

### NOTES

*Wet pipe sprinkler systems must be maintained at a minimum temperature of 40 °F / 4 °C to prevent freezing and bursting of the pipe and/or sprinklers.*

*Automatic sprinklers are not to be tested with a heat source. Operation of the heat responsive element can result.*

*Absence of an Escutcheon Plate may delay the time to sprinkler operation in a fire situation.*

*Before closing a fire protection system main control valve for maintenance work on the fire protection system, which it controls, permission to shut down the affected fire protection system must be obtained from the proper authorities and all personnel who may be affected by this action must be notified.*

*Do NOT enclose sprinklers within drapes, curtains, or valances.*

*Do NOT hang anything from the sprinklers.*

*Do NOT cleanse the sprinklers with soap and water, detergents, ammonia, cleaning fluids, or other chemicals. Remove dust, lint, cobwebs, cocoons, insects, and larvae by gently brushing with a feather duster or gently vacuuming with a soft bristle (i.e., dusting) brush attachment.*

*Exercise suitable safety precautions in the use and storage of highly flammable materials. The rapid rate of fire development and spread of which can be caused by such materials can reduce the ability of the sprinkler system to aid in the control of a fire in which they are involved.*

Sprinklers, which are found to be leaking or exhibiting visible signs of corrosion, must be replaced.

Automatic Sprinklers must never be shipped or stored where its temperature will exceed 100°F / 38°C and they must never be painted, plated, coated, or otherwise altered after leaving the factory. Modified or over heated sprinklers must be replaced.

Care must be exercised to avoid damage to the sprinklers-before, during, and after installation. Sprinklers damaged by dropping, striking, wrench twist / slippage, or the like, must be replaced.

When remodeling, such as by adding false beams or light fixtures or changing the location of compartment walls, first verify that the new construction will not violate the installation requirements stated under WARNINGS. Alter the new construction and/or the sprinkler system to suit the requirements of this document.

The owner is responsible for the inspection, testing, and maintenance of their fire protection system and devices in compliance with this document, the applicable standards of the National Fire Protection Association (e.g., NFPA 25), and the standards of any other authorities having jurisdiction. The installing contractor or sprinkler manufacturer should be contacted relative to any questions.

It is recommended that automatic sprinkler systems be inspected, tested, and maintained by a qualified Inspection Service in accordance with NFPA 25.

## Order Procedure

### **Please Specify:**

Sprinkler Head:

SS2531, Model ZN-UF K=5.6, Commercial Flush Pendent Sprinkler

Finishes:

White Painted, Black Painted, Chrome Plated.

Temp:

162°F, 205°F, and 282°F ( 282°F : UL / ULC Listed only )

Escutcheon:

Escutcheon for ZN-UF Flush Pendent Series.  
(O. D. 3inch/75mm)

Finishes:

White Painted, Black Painted, and Chrome Plated.

Accessories:

- Socket for Model ZN-UF
- Wrench & Socket for Model ZN-UF
- Protective Cap Removal Tool for Model ZN-UF

No. of Parts	Name of Parts	Material	Qua'ty	Remark	No. of Parts	Name of Parts	Material	Qua'ty	Remark
1	Body	CAC406	1		10	Lever	SUS304	2	
2	Frame	CAC406	1	Cr-Plated	11	Balancer	SUS304	1	
3	Deflector	C5191	1		12	Supporting Plate	SUS304	1	
4	Guide Ring	SUS304	1		13	Cylinder	C3604	1	
5	Guide Pin	SUS304	3		14	Plunger	C3604	1	
6	Valve Cap	C3604	1		15	Set Screw	SUS304 or SUSXM7	1	
7	Gasket	C1100 or C1020	1		16	Heat Collector	C1100 or C1020	1	※
8	Coned Coil Spring	SUS304	1		17	Flange Bolt	C1100 or C1020	1	※
9	Saddle	SUS304	1		※Finishes; Bright Chrome Plated Satin Chrome Plated White Painted Black Painted				

Specification

Type	Operating Temperature		Installation Position	Color Code	K-Factor	ID No.
	°F	°C				
ZN-UF 72	162°F	72 °C	Pendent	Uncolored	5.6	SS2531
ZN-UF 96	205°F	96 °C		White		

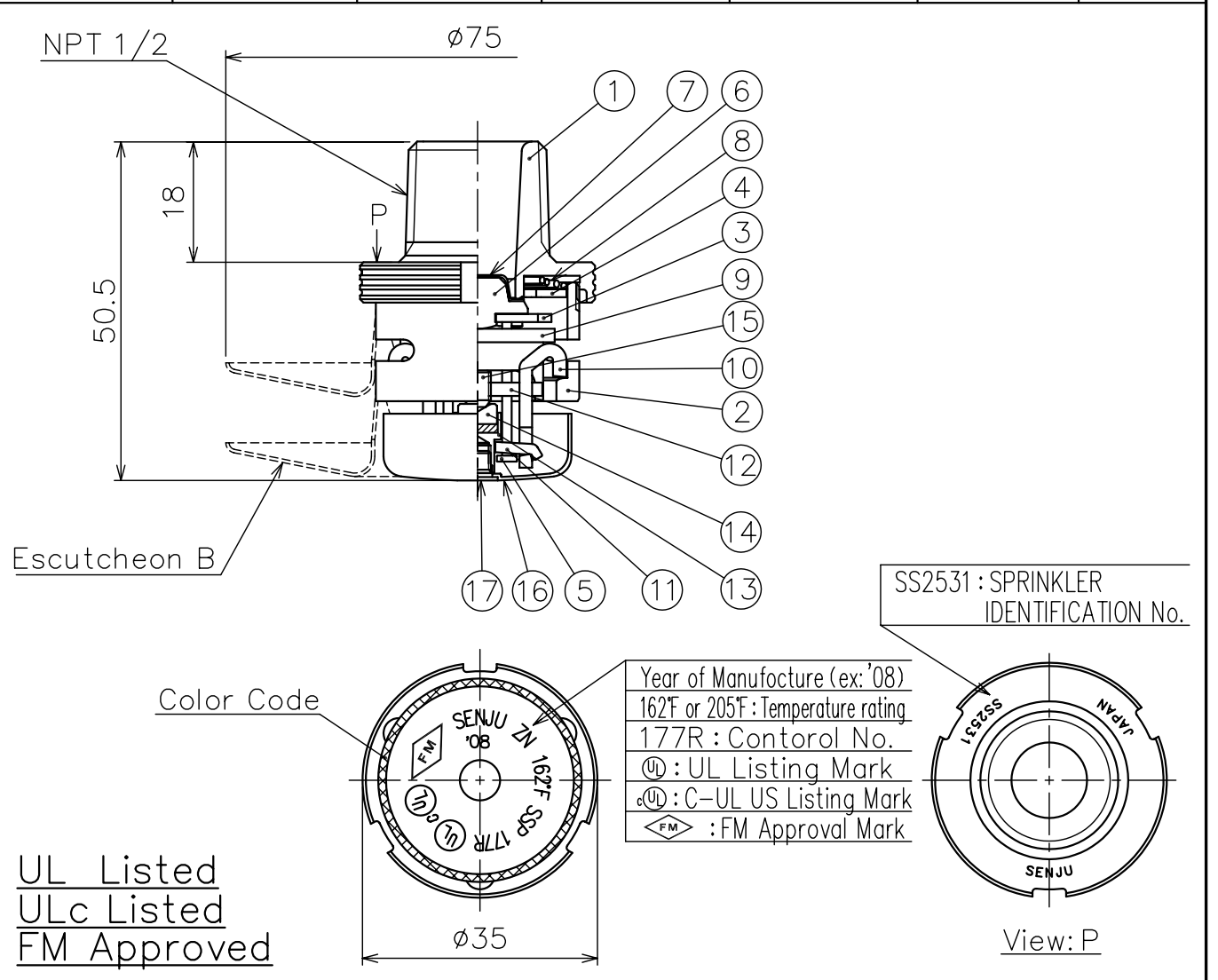

Drawing Name	Issued Date : 08/10/31	Drawn by	A. Onodera	
Automatic Sprinkler Head ZN-UF	Projection Angle	3 r d	Checked by	T. Hatakeyama
	Scale :	1 / 1	Approved by	A. Hotozuka
SENJU SPRINKLER CO.,LTD.	Drawing No.	Revision		
	E013060	G		